



Rotary Form, Fill and Seal Machines FM 200

Intermittently working rotary machines to form, fill and seal flat or stand-up pouches made from reel, also with reclosure systems.

Application range: Food, Pet Food, Beverages, Pharmaceuticals, Nonfood, Household, Personal Care.

- Triplex, Quadro, Quinta, Sexta models also available
- **8 stations** with maximum format range at highest speed, additional equipment (e.g. Nitrogen gassing)
- Up to 20% saving of packaging material
- Servo driven sealing systems
- Easy access for operators
- Compact, modular design
- Up to 3 filling stations for: Slide doser, auger doser, scales, micro doser for smallest volumes, rotary and valve pumpdoser, flowmeter
- Hygienic construction and easy cleaning
- Central operation and visualization via touch screen
- Synchronization with linear and multi-head weigher



*Contract Packing, Liquor Distribution & StandUp Pouch Machinery
Logo for the family of companies in the Group*



**Uniquely customized.
Uniquely economical.**

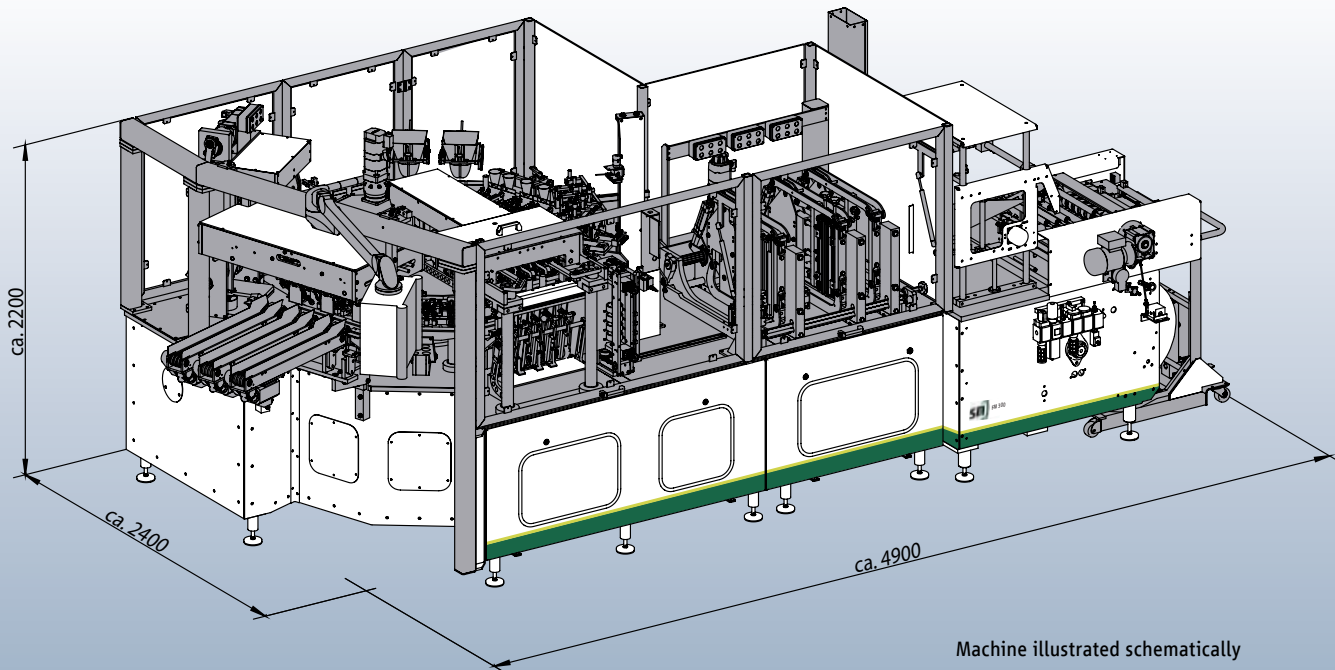

Machine illustrated schematically

Technical details FM 200

Specifications	FM 200 DUPLIX
Pouch size [mm] ¹⁾	Width 100 - 299 Length 120 - 350
Machine output [Pouches/min]	up to 180* * depending on filling characteristics and pouch size
Packing material	sealable laminated film
Construction	Standard to process dry products Optional wash down construction
Safety equipment	Acc. to the international safety regulations e.g. CE , UL, CSA, OSHA
Electricity power [kVA]	ca. 10 - 30 ¹⁾
Electricity supply	3 x 400/230V + N + PE, 50/60 HZ ¹⁾
Voltage [V]	400 / 230 / 24
Air consumption	ca. 1.000 - 1.500 NI/min, 6 bar ¹⁾
Machine dimensions L x W x H [mm]	ca. 4.900 x 2.400 x 2.200 ¹⁾

¹⁾ Depending on configuration. Technical modifications reserved.

Standard equipment	Optional equipment
Pouch control (no pouch – no filling)	Date code systems
Cutting and glueing table	Wash down construction
Film edge control	Ultrasonic sealing
Motor driven roll lifting unit	Reclosure systems
Servo driven sealing systems	Recipe management
Central operation and convenient process control	Reversed image construction
PLC Siemens or Allen Bradley	Nitrogen gassing
Teleservice	(further details on request)



Contract Packing, Liquor Distribution & StandUp Pouch Machinery
 (Logo for the family of companies in the Group)
 PROGRAMMING DEVICES ONLY
 PPI TECHNOLOGIES
 1712 Northgate FL 34266
 (941)359-6678



German
Pouch-Pack
Technology