

Automatic tube filling and sealing machines.

**S 400**

*Up to 4.400 units/hour*



# Technical Characteristics

## S 400



Units/hour

Up to **4,400**

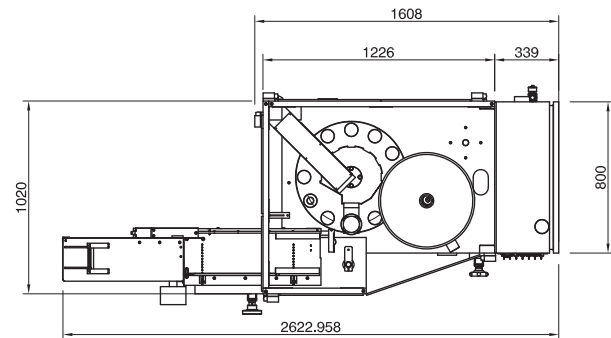
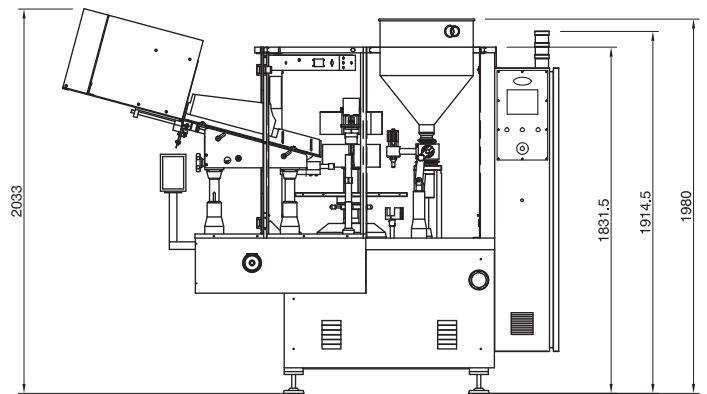

Descriptions and pictures of this brochure are given for information only and can be modified without prior notice.

Tube Dimensions		Metal	Plastic
Tube size -		Metal	Plastic
Diameter -	mm	min-max 10-42	min-max 10-50 (60)
Length -	mm	50-240	50-240

Consumption		Metallo	Plastica
Consumption -		Metal	Plastic
Water -	l/min	min-max -	min-max 1-2
Air -	l/min	150	300
Power -	kW	2	5.5



**TGM - TECNOMACHINES s.r.l.**

Via delle Industrie, 104 - 24059 URGANO (BG) Italy - Tel. +39 035 893135 - Fax +39 035 893151 - www.tgm.it - info@tgm.it